

AFRL

THE AIR FORCE RESEARCH LABORATORY
LEAD | DISCOVER | DEVELOP | DELIVER

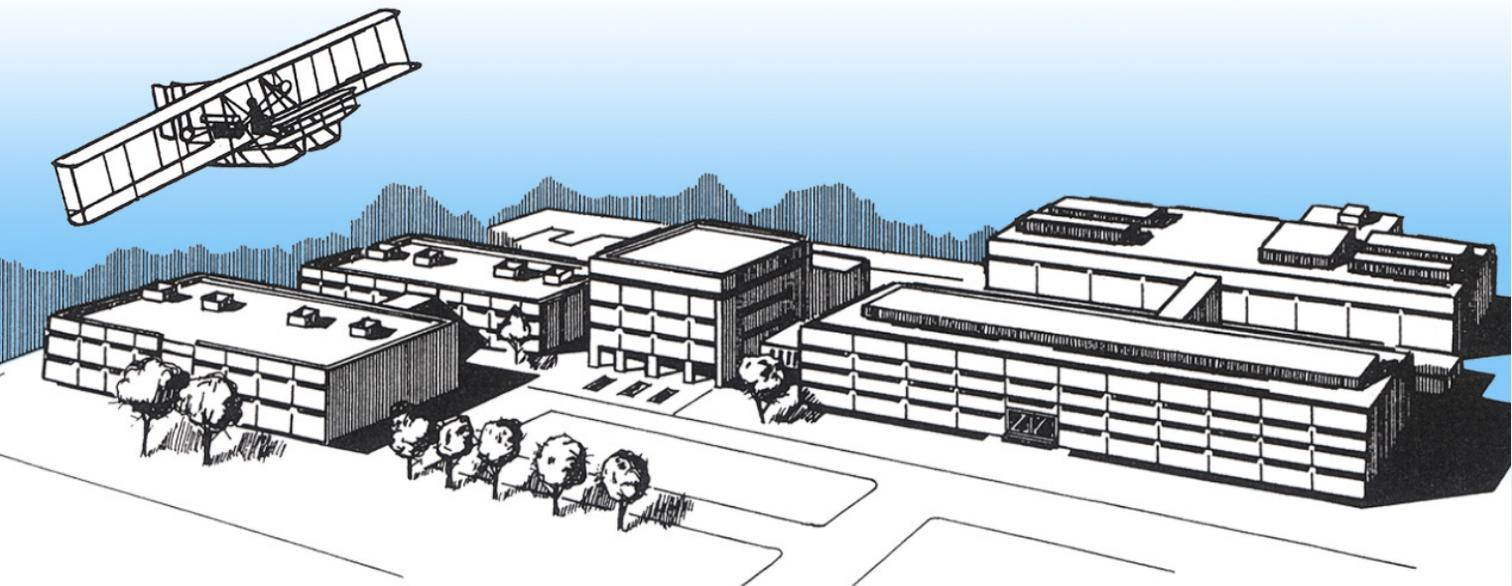

THE MATERIALS AND
MANUFACTURING DIRECTORATE



About This Book

This book highlights the Air Force Research Laboratory's Materials and Manufacturing Directorate in being the foundational, principle expert for warfighter material needs. Materials, processes, and manufacturing are frequently enablers for technology advances and often barriers to technological progress. The following pages provide a brief insight into the directorate and feature the mission, capabilities, and staff that help keep the United States Air Force the finest flying force in the world.

Our Vision

World Class Leadership in Materials and Manufacturing for our Airmen

We understand the warfighter's needs.

We understand the state of the art.

We connect, develop, and exploit science and technology.

Our Mission

Drive United States Air Force systems innovation, design, production, operation, and sustainment by coupling computation and experiment to envision, create, deliver, and support materials and manufacturing solutions for our Airmen.

Table of Contents

About This Book	2
Our Vision & Mission	3
Supporting the Air Force	5
Organizational Structure	6
Workforce	7
From Start to Finish	8-9
Functional Materials	10-11
Structural Materials.....	12-13
Manufacturing and Industrial Technologies	14-15
Systems Support	16-17
Research Teams.....	18-19
Unique/World-Class Experimental Facilities.....	20-21
Working with Us.....	22
Technology Transfer	23
Stem Outreach -Developing the Next Generation Workforce.....	24-27



Supporting the Air Force

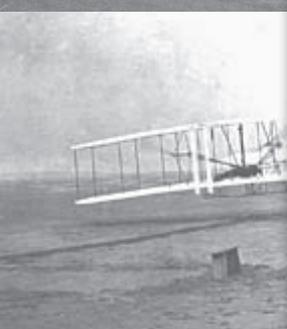

For over 100 years, the mission of the Materials and Manufacturing Directorate of the Air Force Research Laboratory has remained the same. In peace and in wartime, during economic growth and through recessions and the Depression, under many different names and in different locations, it has supported Air Force operations, developed materials and manufacturing technologies for Air Force customers, and created new materials and processing technologies that enable future capabilities. Building upon a direct heritage from Orville and Wilbur Wright – the founders of aviation – the Materials and Manufacturing Directorate helps build the world's most powerful Air Force. Along the way, it has contributed significantly to the economic strength of the United States by creating many major technology advancements,

enabling U.S. industries to thrive and surpass international competition.



RX has consistently achieved this daunting, top-level mission by weaving together three interconnected roles: The Materials and Manufacturing Directorate is a laboratory; it is a technology contract organization; and it is a rapid-response support organization. It is also a trusted advisor to national leadership to help establish technology policy for the Department of Defense. Connecting these different roles hasn't always been easy, and to many outside of the laboratory it can seem a little unusual that so many roles are funneled into a single organization. However, these roles produce a dynamic atmosphere that synergize into a whole that's greater than any individual part.

Organizational Structure

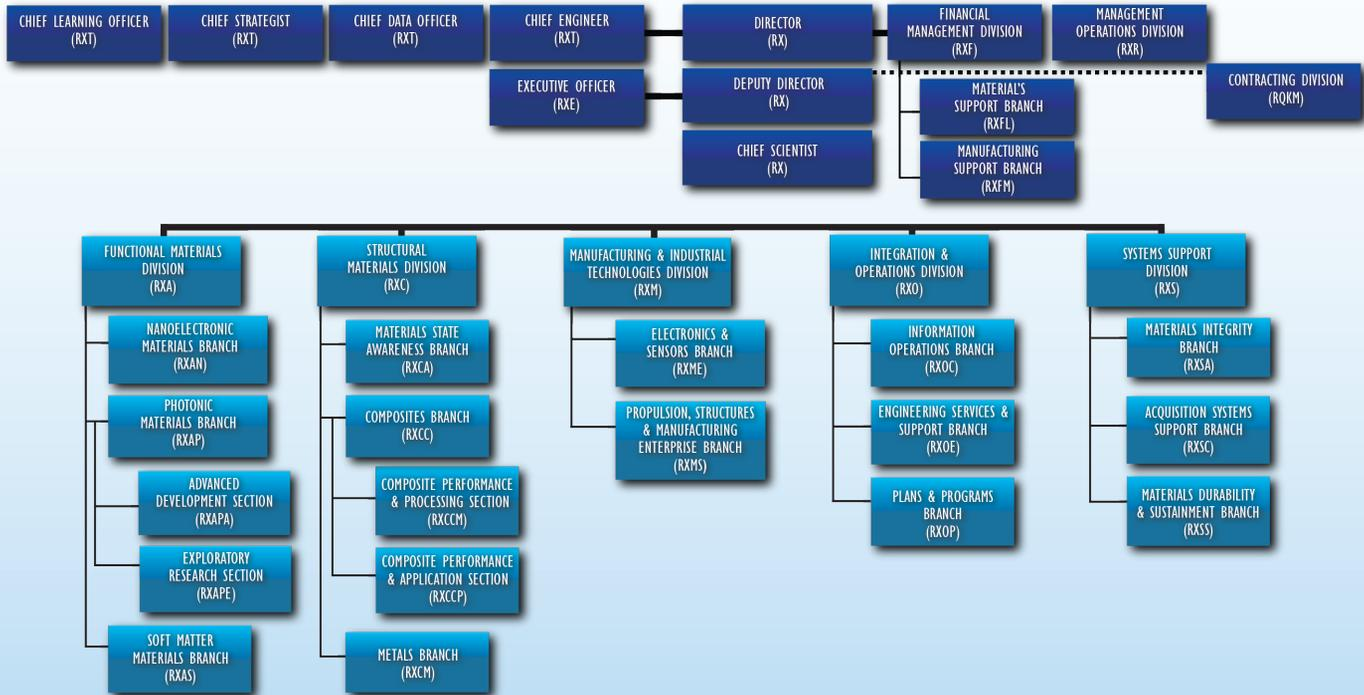

Workforce

PERSONNEL (as of October 2018)



Contractors (S&Es, Technicians,
Students, Ops Support)
595 (FTE Equivalent)- 339 PhDs



Civilian

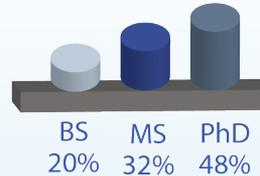

Military

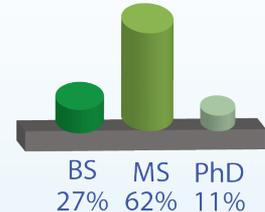

DEGREES AND SPECIALTY AREAS

Materials/Metallurgical Eng.
Chemists/Chemical Engineers
Research Physicists
Mathematicians
Human Factors Engineers
Aero/Astro Engineers

Civil/Industrial Engineers
Biologists/Microbiologists
Mechanical Engineers
Computer Eng./Computer Science
Electrical Engineers
Ops Research/Systems Eng.



From Start to Finish...

Our **people, programs,** and **partnerships** provide **unique** expertise in materials and manufacturing science and technology critical to **all phases** of an Air Force weapon system's **life cycle**—from discovery and conceptual design through manufacturing, production, operations, sustainment, and disposal.

We are entrusted stewards of Air Force research and development funding, focusing efforts on moving technologies/capabilities to warfighters quickly and affordably while fulfilling near, mid, and far-term needs.

The science and technology portfolio of the AFRL Materials and Manufacturing Directorate is comprised of four Core Technical Competencies (CTCs):

- **Functional Materials and Applications**
- **Structural Materials and Applications**
- **Manufacturing and Industrial Technologies**
- **Support for Operations**

Each play a vital part in our role as the Air Force's materials and manufacturing experts.

Other focus areas involve aerostructures, airman performance, energy assurance/efficiency, sensors, support to safety investigations and mishap prevention, munitions, and space.

Using an **Integrated Computational Materials Science and Engineering** standard, we integrate experimental, computational, and informatics tools while enabling rapid design.

The following pages highlight each CTC.

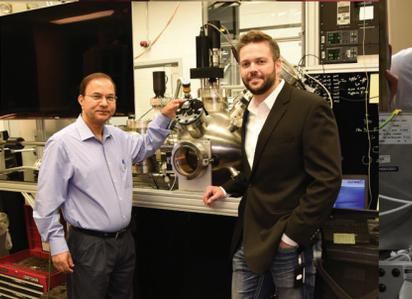
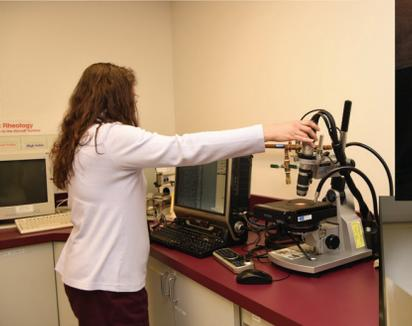
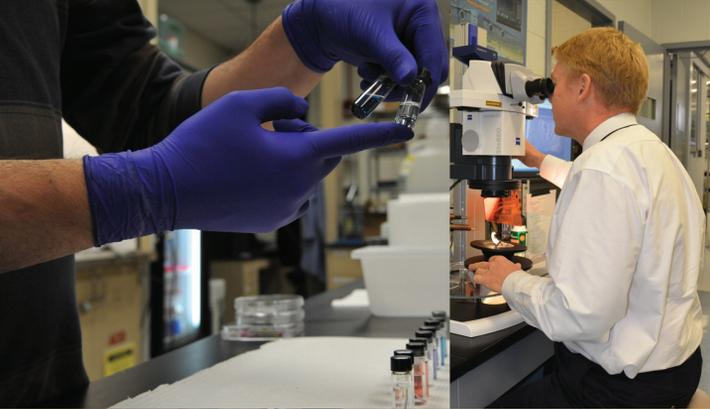
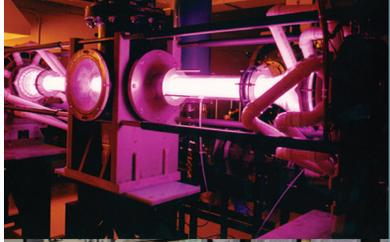

FUNCTIONAL MATERIALS

The Functional Materials Division is one of the two 'research-centric' divisions which possess extensive in-house laboratory capabilities and lab scientists and engineers. This is balanced with an external development program with industry and other government partners. The Functional Materials Division works crucial materials and associated processing technologies for next-generation fight-through-capability and warfighter-system teaming.

These materials control and generate information and energy. This includes photons for communication, sensing, or directed energy; electrons for radio frequency or data processing; and biology and chemistry for interfacing the warfighter with our machines.

NANOELECTRONIC MATERIALS

Materials and processes for advanced intelligence, surveillance, reconnaissance (ISR), and electronic warfare (EW) systems

High power and reconfigurable electronic materials, materials for reduced cost, size, weight, and power radio frequency (RF) systems, and materials for infrared sensing and quantum information

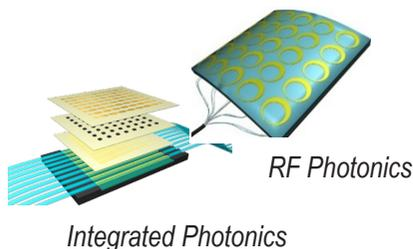

RF Photonics

Integrated Photonics

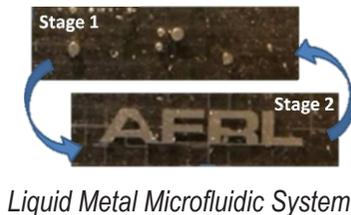

Liquid Metal Microfluidic System

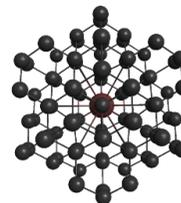

Quantum Light Sources



PHOTONIC MATERIALS

Optical materials for hardening against and generation of directed energy

Structured optical materials, coatings, switchable filters, electron emission, nonlinear optics, characterization of light-matter interactions, and demonstration of advanced technologies



Night Vision Goggle Optic, Damaged and Protected



Non-linear Optical Materials

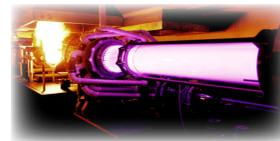

Laser Hardened Materials Evaluation

SOFT MATERIALS

Polymers, chemistry, nanoparticles, printing and biology

Stretchable/conformal circuits, encapsulation of vaccines for remote deployments, revolutionary concepts to sense bio-macromolecular readiness, and to determine the impact of microbes on Air Force systems



Flexible / Wearable Bio Sensors



Microbiologically Produced Photonic Materials

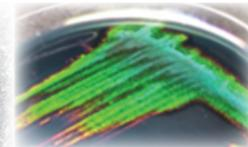

STRUCTURAL MATERIALS

The Structural Materials Division is one of the two 'research-centric' divisions which possess extensive in-house laboratory capabilities and lab scientists and engineers. This is balanced with an external development program with industry and other government partners. The Structural Materials Division works materials technologies that enable increased performance and/or flight efficiency, reduce variability and defects in processing, and lower lifecycle costs in applications that cover the full range of Air Force systems. These materials are used primarily for their mechanical and load-bearing properties. This includes a materials response to an applied force, whether elastic or plastic, its hardness, and its strength.

MATERIALS STATE AWARENESS

Improve detection and enable characterization of initial and evolving state of materials in fielded and future Air Force systems

Characterization, sensing, and analytics; nondestructive evaluation (NDE) for turbine engines; NDE for aircraft structures; specialty materials NDE



*Remote
Access NDE*



*Handheld
Imaging Tool*

COMPOSITE MATERIALS

Organic and ceramic matrix composite technologies for increased performance and efficiency, reduced cost, and accelerated manufacturing

Expendable thermal protection; composites certification; multifunctional/hybrid structures; integrated computational methods for composites; structurally integrated thermal protection; composites for turbine engine components; advanced directed energy technologies



*Materials, processing,
and survivability for
extreme environments*

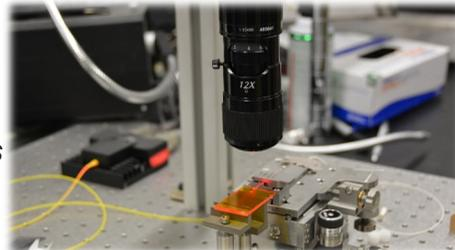

METALS

Metallic materials technologies for increased performance and efficiency, reduced cost, and accelerated manufacturing

Next-gen disk for energy efficient propulsion; metals probabilistic performance prediction; propulsion risk management; additive manufacturing; residual stress management; metals materials and processing



*Additive
Manufacturing*



*3-D Materials
Characterization*

MANUFACTURING AND INDUSTRIAL TECHNOLOGIES

The Manufacturing and Industrial Technologies Division (known as MANTECH) uses U.S. industry as its laboratory. It's responsible for planning and executing programs that grow the nation's defense industrial base in support of Air Force weapon system development and sustainment requirements.

This ensures advanced manufacturing processes, techniques, systems, and equipment are available for timely, reliable, economical acquisition, production, and systems repair.

ELECTRONICS AND SENSORS

Establish capability to affordably manufacture sensors, electronic devices, assemblies, and subsystems for Air Force and DOD weapon systems

Manufacturing of Command, Control, Communication, Computer, Intelligence, Surveillance and Reconnaissance (C4ISR) Systems
Component Manufacturing; Advanced Electronics Manufacturing Processes



Reconfigurable ISR Pod



Advanced Solar Cell Production



Sensor Components



Material Growth

PROPULSION, STRUCTURES, AND MANUFACTURING ENTERPRISE

Establish and improve production capability of Air Force and DOD weapon system engines in response to Air Force and DOD needs

Manufacturing of Propulsion Systems; Manufacturing of Aerospace Structures; Manufacturing of Air Armaments,
Manufacturing for Agile Sustainment

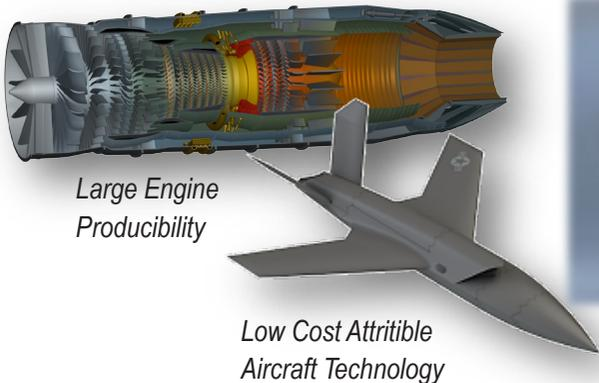

*Large Engine
Producibility*

*Low Cost Attritable
Aircraft Technology*

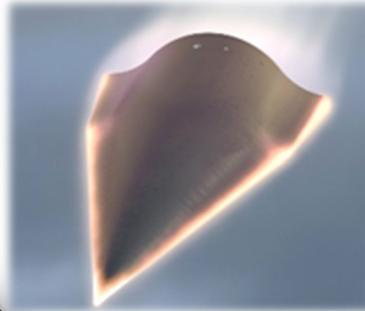

*Carbon-Carbon Aeroshell
for Hypersonic Vehicles*



*Additive Manufacturing
for Sustainment*

SYSTEMS SUPPORT

The Systems Support Division aims to be the Air Force resource of choice for delivering quick-reaction, unbiased scientific materials and processing support to keep new and legacy weapon systems safe, available, and affordable. It supports a wide range of Air Force customers throughout the lifecycle of weapon systems. The division conducts structural and electronic root cause/failure analysis for mishaps, recommends fixes, and provides lessons learned to developers and end users. When requested, it also rapidly engineers solutions, conducts development programs for near-term needs, and provides transition support to deliver technologies to the warfighter.



MATERIALS INTEGRITY

Provide time-critical materials and processing (M&P) support. Investigate M&P related issues for aerospace vehicle accidents and solve problems associated with operational and experimental Air Force Systems

Electrical and electronic materials evaluation; structural materials evaluation; adhesives and composites; chemical analysis



Mishap Investigations

ACQUISITION SYSTEMS SUPPORT

Provide on-site M&P engineering support to select Air Force program offices and execute the Advanced Power Technology Office program to transition and integrate alternative energy technologies into the Air Force inventory

Advanced power technology; M&P co-locates in system program offices



Forward Operating Base of the Future



Advanced Wind Demo

MATERIALS DURABILITY AND SUSTAINMENT

Deliver rapid technical support to resolve sustainment issues through the application of best practices or advanced M&P technologies

Coatings and erosion; corrosion; specialty material affordability; Elastomers



Optimized Coatings and Application



Supersonic Rain Erosion Testing (Mach 2+)

RESEARCH TEAMS

The Materials and Manufacturing Directorate funds 12 research teams across a variety of materials science competencies in the two research-centric divisions. These teams are peer-led and consist of varying numbers of government Scientists and Engineers (S&Es) supported by a number of staff scientists, post-doctoral associates, and full and part-time students. The focus is on early Technology Readiness Level (TRL) activities, primarily on-site in the extensive research facilities and growth of government technical experts with deep technical roots. These teams are the major interface to the Air Force Office of Scientific Research (AFOSR), National Science Foundation (NSF), and our academic linkages and to subject matter experts across the Army and Navy defense laboratories and other national laboratories.

PMC Materials & Processing

- *Composite Processing Science*
- *Multifunctional Composite Structures*

Ceramics Materials & Processing

- *Fiber Reinforced Composites*
- *Environmental Effects*

Composites Performance

- *Continuous Fiber Reinforced Composite Behavior & Life Prediction*
- *Ceramic Matrix Composite Durability in Extreme Environments*

Metals Materials & Processing

- *Processing Science*
- *Process Modeling*

Metals Probabilistic Performance Prediction

- *High temperature durability assessment*
- *Location-specific (microstruct-sensitive) probabilistic property prediction*

Characterization Sensing and Analytics

- *Materials characterizations across all lengths scales focus on nondestructive and destructive needs*
 - *Physical metrics accuracy and uncertainty quantification*

RESEARCH TEAMS

Biological Materials & Processing

- *Biomacromolecular-Material Interactions*
- *Microbial-Material Interactions*

Flexible Materials & Processing

- *Additive Processes
for Compliant Packages*
- *Strain-Tolerant Materials
and Nanostructures*

Integrated Opto-Electronic Material & Processing

- *Infrared Detectors & Quantum Sources*
- *Integrated Photonics*

Agile RF Electronic Materials & Processing

- *High Power & Frequency
Electronic Materials*
- *Reconfigurable RF Materials*

Structured Optical Materials & Processing

- *Responsive Optical Material Systems*
- *Optical Thin Films and Coatings*

Non-Linear EM Materials & Processing

- *Source Materials*
- *Broadband Nonlinear Materials*

UNIQUE/WORLD-CLASS EXPERIMENTAL FACILITIES

Autonomous Research Systems (ARES)

- 1st-ever Robot Researcher for carbon nanotube synthesis using artificial intelligence and automation
- Capable of conducting experiments, analyzing results and deciding which experiments to do next

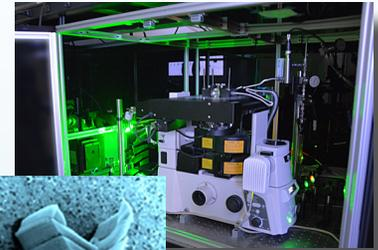

Supersonic Rain Erosion Rig

- One-of-a-kind test facility enabling testing of full-scale components
- Propels 2mm raindrops up to Mach 2.3 to evaluate rain erosion properties

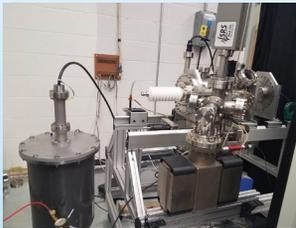
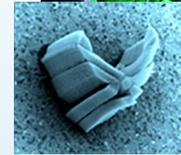

High Power Microwave (HPM) Materials Characterization System

- In-house designed system for evaluating advance nanostructured electrode materials for improved performance & reduced Size, Weight and Power (SWAP) for next generation HPM Weapon Systems



Microbe-Materials Interaction Lab

- Supports growth and analysis of microbial (fungal, bacterial) cultures and biofilms capable of material degradation
- Only BioSafety Level-2 (BSL-2) lab in AFRL

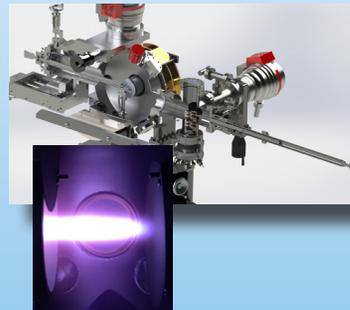

High Throughput, Epitaxial Growth System

- One-of-a-kind deposition system to create extremely high-quality electronic materials for agile and high power RF/microwave systems

UNIQUE/WORLD-CLASS EXPERIMENTAL FACILITIES

Nano Computed Tomography (CT)

- 50 nm spatial resolution....1st in US academic/government setting
- Provides non-destructive 3D morphology of complex materials
- High contrast to quantify internal structure



Secondary Ion Mass Spectrometry (SIMS)

- Provides elemental, chemical state, and molecular information from surfaces of solid materials and thin films
- Allows design of materials in-house

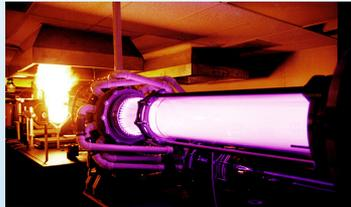

Laser Hardened Materials Evaluation Laboratory (LHMEL)

- High-temp characterization of Materials exposed to laser sources
- Nation's largest Continuous Wave (CW) CO₂ Infrared (IR) Laser

Special Test and Research (STAR) Lab

- One-of-a-kind facility to provide the US government with independent capability for specialty material development evaluation, and failure analysis

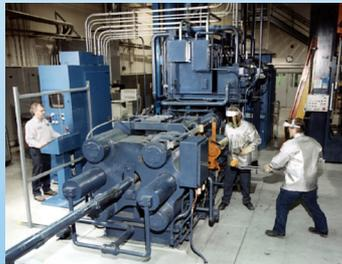

High Bay Materials Processing Facility

- Improved aerospace materials processing
- Computer controlled extrusion

WORKING WITH THE MATERIALS AND MANUFACTURING DIRECTORATE

Whether you own a small business, teach at a university, or you're working with a prime defense contractor, the Materials and Manufacturing Directorate has agreements that will work for you. We rely on the collaborations we have with our valuable partners and we encourage you to work with us to solve some of the Air Force's toughest science and technology challenges. Together, we can ensure our warfighters never go into a fair fight.

Materials and Manufacturing Broad Area Announcements (BAA)

The Materials and Manufacturing Directorate has Broad Area Announcements (BAA) which list research areas that may be of interest to potential partners. The most current BAAs can be found by typing "AFRL/RQK Solicitations on FBO" into your internet search engine and choosing the FedBizOpps link. White papers can be submitted any time during the open BAA period.



Air Force Independent Research and Development (IR&D)

The Air Force IR&D Program was developed to provide a way for the Air Force to inform industry of warfighting capability gaps and technology needs, and to enable industry to inform Air Force warfighters, acquirers, and science and technology developers of its research and development portfolios and corporate investments. Air Force IR&D effectively uses the Defense Innovation Marketplace defenseinnovationmarketplace.mil, known as "Marketplace") as its primary means for exchanging critical data at different levels of security and distribution.

Air Force Small Business Innovation Research (SBIR) and Small Business Technology Transfer (STTR)

The Air Force SBIR/STTR program is designed to stimulate the research efforts of small businesses and universities, while providing the Air Force with cost-effective technical solutions to challenging Air Force problems. This program also encourages small businesses to market their SBIR/STTR tech in the private sector. Learn more at www.afsbirsttr.com



The Wright Brothers Institute

Wright Brothers Institute (WBI) is a non-profit organization that facilitates knowledge transference between the Air Force Research Laboratory (AFRL), academia, industry and the region. The institute provides a variety of services in its 58,000 square feet of space to ideate, collaborate and create solutions through workshops and prototype development.

TECHNOLOGY TRANSFER (T2)

The Air Force Technology Transfer program assures that the Air Force science and engineering activities promote the transfer and/or exchange of technology with state and local governments, academia, and industry to create jobs, improve productivity, and increase competitiveness while supporting the Air Force mission.

Partnering with the Air Force is readily accomplished through a variety of agreements. These partnerships can be in the form of collaborative research, testing of innovations or products, providing excess equipment to schools, or licensing Air Force technologies. The agreements protect the partner while allowing Air Force resources to focus activities on solving common problems and advancing technical solutions.

The Cooperative Research and Development Agreement (CRADA) is one of several mechanisms utilized by the T2 program. It is flexible, convenient, and available in various formats to meet the needs of partners and Scientists and Engineers (S&Es). CRADAs can be in the form of traditional research and development agreements, facilities, or limited purpose such as for Software Use Agreements (SUAs) or Material Transfer Agreements (MTAs).

Educational Partnership Agreements (EPAs) are another mechanism used specifically for agreements between defense laboratories and educational institutions. Key benefits for educational institutions include access to government equipment and resources as well as opportunities to collaborate with top-notch S&Es. Collaboration is beneficial for both parties, enabling S&Es to gain insight from an outside perspective and an opportunity to engage and grow the future technical workforce.

The Materials and Manufacturing Directorate T2 program offers partners an outstanding opportunity to leverage directorate technology and expertise to achieve solutions and realize significant cost savings while enhancing economic competitiveness. It's a unique chance to work directly with Air Force scientists and engineers and an invitation to take advantage of specialized research and development facilities and equipment. For more information about the T2 program, please visit www.wpafb.af.mil/t2



License agreements in effect through the Air Force T2 program generate a measurable impact on the national economy. In a study of the 11-year period through 2011, T2 contributed to new economic activity and job creation in the U.S. while driving the transition of new technology to U.S. military use.



STEM OUTREACH – DEVELOPING THE NEXT GENERATION WORK FORCE

Preparing the next-gen workforce for careers in science and technology is vital to ensure future research and development for national defense. The Air Force provides many opportunities for on-the-job training and career preparation in science, technology, engineering, and mathematics (STEM) disciplines for college and university students and faculty, recent graduates, and even those still in middle and high school. The following programs offer a variety of challenging and awarding experiences worth considering.

Air Force LEGACY Program – Middle School Through College Students

Leadership Experience Growing Apprenticeships Committed to Youth - The LEGACY program is three phases designed for students from sixth grade to completion of their bachelor's degree. LEGACY is intended to introduce STEM at a young age, continue growing students' interest in STEM, and eventually hire these students into a STEM driven Air Force career. More information is available at wpafbstem.com/pages/legacy.html



Wright Scholar Research Assistant Program – High School Students

This is an Air Force Research Laboratory initiative designed to expose high school juniors and seniors to various disciplines of engineering and science in an effort to further their interest in future STEM career options. Wright Scholars are employed as full-time, paid interns for 9 weeks during the summer. Students are competitively selected to work on a research project under the guidance of their assigned mentors. They also participate in weekly workshops, lectures, and tours to expand their knowledge of potential science and engineering career fields. At the end of the program, Wright Scholars are required to present their project work to their peers and mentors, and a program certificate is awarded. Find out more at wpafb.af.mil/Welcome/Fact-Sheets/Display/Article/985968/wright-scholar-research-assistant-program

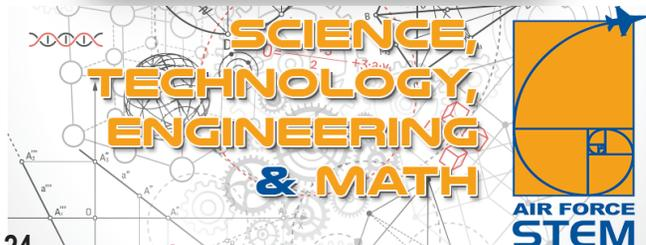



Pathways Program – College Students

The Pathways Program offers federal internship and employment opportunities for current college students, recent graduates, and those with an advanced degree. There are several paths available and those who complete the program may be eligible for conversion to permanent civil service employment. The most up-to-date information can be found at usajobs.gov/studentsandgrads

Students from Community Colleges Gaining Experience and Skills in STEM (SUCCESS) – Community College Students

The Air Force Research Laboratory's SUCCESS program is designed as a vehicle to introduce community college students to the Air Force Research Laboratory and the larger Air Force to gain real world STEM experience. During the year-long program, students receive a salary and tuition assistance. Upon completion, their government supervisor can take over funding requirements and potentially hire the student into a full-time position. Find more info at usajobs.gov/studentsandgrads



PALACE Acquire – College Students

The PALACE Acquire program enables the Air Force to provide entry-level STEM opportunities to competent, highly-qualified individuals outside of the Air Force, and to help identify and educate potential future Air Force leaders. Specifically, the program was established to heighten Air Force STEM's ability to maintain the leading edge in today's technology-intensive environment by hiring dynamic, creative, and innovative scientists and engineers. There are two tiers to this program depending on the level of education that you have at the time of application. There is a program for recent Bachelor of Science (BS) graduates and a program for recent Master of Science (MS) graduates.

Find more info at usajobs.gov

Southwestern Ohio Council for Higher Education (SOCHE) – College Students

SOCHE's Student Research Program provides year-long research internships at Wright-Patterson Air Force Base for undergraduate and graduate STEM students at either the Air Force Institute of Technology or the Materials and Manufacturing Directorate at the Air Force Research Laboratory. Find more info at socheinern.org/

Department of Defense Science, Mathematics & Researcher Transformation Scholarship for Service Program (SMART) – College Students

SMART was established by the DOD to support undergraduate and graduate students pursuing technical degrees in STEM disciplines. The program aims to increase the number of civilian scientists and engineers working at DOD laboratories, including the Air Force Research Laboratory. Learn more at smartscholarship.org/

AFRL Summer Faculty Fellowship Program – College and University Faculty

The Lab Summer Faculty Fellowship Program offers hands-on exposure to Air Force research challenges through eight- to 12-week research residencies at participating Air Force research facilities for full-time STEM faculty at U.S. colleges and universities. More info is available at afsffp.sysplus.com/

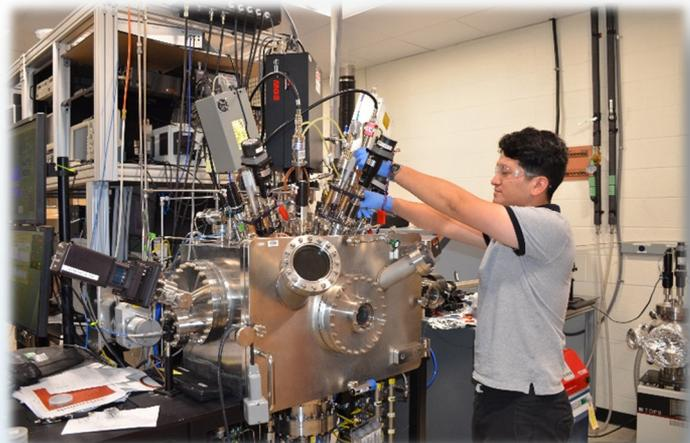

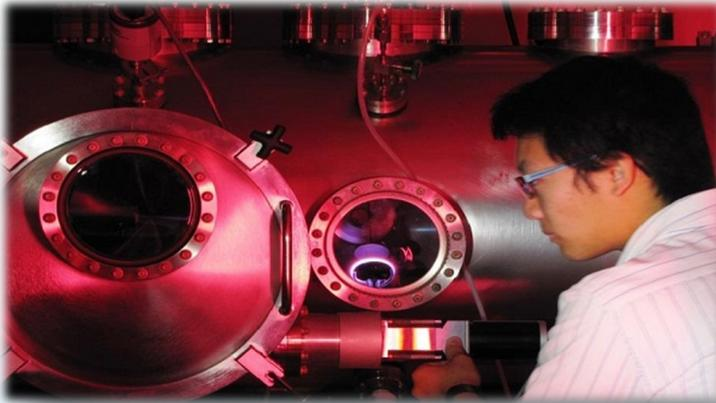

**AFRL/Dayton Area Graduate Studies Institute (DAGSI)
Ohio Student-Faculty Research Fellowship Programs –
College Graduate Students and Faculty Members**

This program supports graduate science and engineering students and faculty who conduct research in areas targeted by the Air Force Research Laboratory at Wright Patterson Air Force Base. Through one-year fellowships, it aims to strengthen AFRL research ties to Ohio's academic science and engineering community, leverage Ohio research funding with AFRL, university, and industry funding and other resources, and develop research talent to meet AFRL and Ohio high-tech workforce needs. Learn more at dagsi.org/



**National Research Council (NRC) Research Associate
Programs – Graduate Students, Postdoctoral
Researchers, and Senior Level Researchers**

The NRC Research Associateship Programs promote excellence in scientific and technological research conducted by the U.S. government through the administration of programs offering graduate, postdoctoral, and senior level research opportunities at sponsoring federal laboratories and affiliated institutions. Awards include stipends, health insurance, and professional travel and relocation. Learn more at sites.nationalacademies.org/pga/rap/

AFRL Materials and Manufacturing Directorate

2977 Hobson Way

Wright-Patterson AFB, OH 45433

For more information about the Materials and Manufacturing Directorate, please visit <http://www.wpafb.af.mil/afrl/rx> and https://community.apan.org/wg/afrl_materials or email us at AFRL.RX.CorpComm@us.af.mil

For more information about AFRL, please visit AFResearchlab.com

